

## **SDN-xW (-EX-MV & -EX-IR) Series**

PWM Solar Charge Controller with Built-in LED Driver

With Motion Sensor of MicroWave and Infrared

# USER MANUAL

### **Compatible Models:**

MicroWave:

SDN-40W-EX-MV; SDN-60W-EX-MV

SDN-100W-EX-MV;SDN-150W-EX-MV;

SDN-200W-EX-MV;

Infrared:

SDN-40W-EX-IR; SDN-60W-EX-IR

SDN-100W-EX-IR;SDN-150W-EX-IR;

SDN-200W-EX-IR;

**High Technology Create A Better Life!**

---

## **Preface**

Thank you very much for selecting our product!

This manual offers important information and suggestions with respect to installation, use and troubleshooting, etc.

Please read this manual carefully before using the product and pay attention to the safety recommendations in it.

Contents of this manual are subject to change without notice, and updates will be added in the new version of the user manual.

For ease of reference, please take good care of this manual

---

# Contents

---

|   |       |
|---|-------|
| 1. Products Introduction.....                         | 4     |
| 1.1 Product Description.....                          | 4     |
| 1.2 Main Features.....                                | 4     |
| 1.3 Technical Parameters.....                         | 5     |
| 1.4 Dimension.....                                    | 6     |
| 2. Installation.....                                  | 7     |
| 2.1 Panel Introduction.....                           | 7     |
| 2.2 LED Indicators.....                               | 8     |
| 2.3 Fix the controller.....                           | 9     |
| 2.4 Connection method.....                            | 9-10  |
| 2.5 Connection step.....                              | 11    |
| 3. Instructions.....                                  | 12    |
| 3.1 Charge description .....                          | 12-14 |
| 3.2 Discharge description.....                        | 14-16 |
| 4.Trouble Shooting.....                               | 18    |
| 5.Protection.....                                     | 19-20 |
| 6. IR Remote Control.....                             | 21    |
| 6.1 Diagram.....                                      | 21    |
| 6.2 Operation of remote control.....                  | 21-23 |
| 6.3 Introduction for different controller models..... | 24-26 |
| 6.4 Real-Time Data.....                               | 26    |
| 6.5 System Setting.....                               | 26-27 |
| 6.6 Additional function.....                          | 27    |
| 6.7 Appendix.....                                     | 27    |
| 7.Warranty.....                                       | 28    |

---

# Products Introduction

## **1.1 Product Description**

SDN series solar controller built in led driver, powered by solar energy, combines solar battery charging / discharging management function and LED light source constant-current driving mechanism. It's widely used for solar street lamps and solar courtyard lighting system.

This product series is used to manage charging of battery with solar panels, discharging of loads with battery, constant-current driving of LED lamp holder, and power control and the motion sensor function.

Multiple operation modes are provided including automatic mode, light-control mode, and manual mode. A test mode is also available for engineering installation.

## **1.2 Main Features**

- 6 Times periods Load Control(Timer+Dimmer)
- Intelligent system for environmental monitoring,automatic adjustment of power,effectively extending the battery life.
- Automatic 12v/24v Detection
- Three-stage battery charging with PWM
- Compatible with Gel,AGM,Lead acid,Lithium(LiFePO4 &Li-ion) or your own battery type(DIY)by remote control setting.
- Waterproof IP67, Aluminum housing for better cooling
- Max output efficient of 96%
- -40°C~+55°C Wide temperature range
- Motion sensor function with microwave or Infrared
- RS485 communication port can be added before factory(optional)

### 1.3 Technical Parameters

| Model                             | SDN-40W-EX-MV  | SDN-60W-E X-MV     | SDN-100W-EX-MV      | SDN-150W-EX-MV      | SDN-200W-EX-MV       |
|-----------------------------------|--|--------------------|---------------------|---------------------|----------------------|
|                                   | SDN-40W-EX-IR  | SDN-60W-E X-IR     | SDN-100W-EX-IR      | SDN-150W-EX-IR      | SDN-200W-EX-IR       |
| System voltage                    | 12V24V auto  |                    |                     |                     |                      |
| Output power                      | 40W/12V<br>40W/24V   | 60W/12V<br>60W/24V | 50W/12V<br>100W/24V | 75W/12V<br>150W/24V | 100W/12V<br>200W/24V |
| Discharge Method                  | Boosting Constant Current  |                    |                     |                     |                      |
| Output voltage                    | 17~55V/12V;29~55V/24V<br>(Vin+5V)~55V (Vin is the battery voltage) |                    |                     |                     |                      |
| Output waveform                   | ≤600mV   |                    |                     |                     |                      |
| Max input current                 | 10A  | 15A                | 15A                 | 20A                 | 20A                  |
| Max output current                | 2.0A   | 3.3A               | 3.3A                | 6.6A                | 6.6A                 |
| Output Constant current precision | <3% (typical) , above 80% rated power<1%                           |                    |                     |                     |                      |
| Typical efficiency                | 92~96%   |                    |                     |                     |                      |
| Work temperature                  | -35~55℃ (-40~90℃ customized)                                       |                    |                     |                     |                      |
| No load current                   | ≤5~15mA  |                    |                     |                     |                      |
| Temperature compensation          | -5mv/℃/2V (charge voltage,over discharge voltage compensation)     |                    |                     |                     |                      |
| Control mode                      | PWM+smart High Frequency Modulation software                       |                    |                     |                     |                      |
| Appearance size                   | 88*53*21mm   | 88*83*21mm         |                     | 110*100*25mm        |                      |
| Install Hole Size                 | Φ3.5   |                    |                     |                     |                      |
| Weight                            | 0.18 kg  | 0.26kg             |                     | 0.5kg               |                      |

## 1.4 Dimension

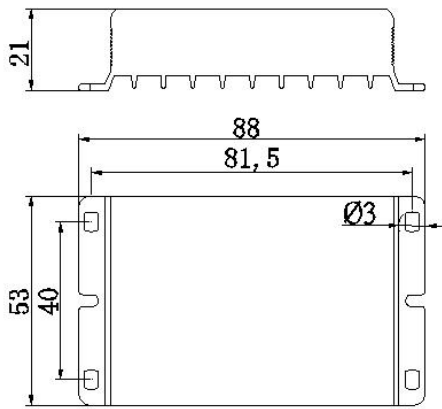

SDN-40W-EX-MV  
SDN-40W-EX-IR

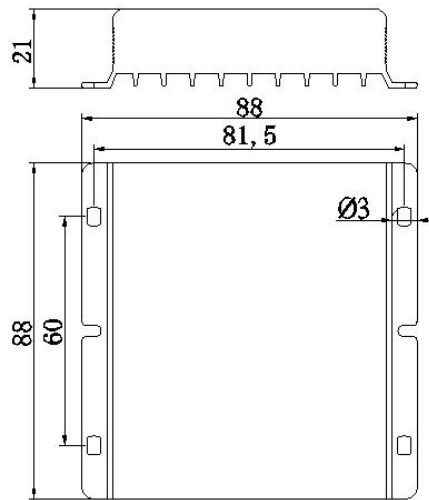

SDN-60W-EX-MV; SDN-100W-EX-MV;  
SDN-60W-EX-IR; SDN-100W-EX-IR;

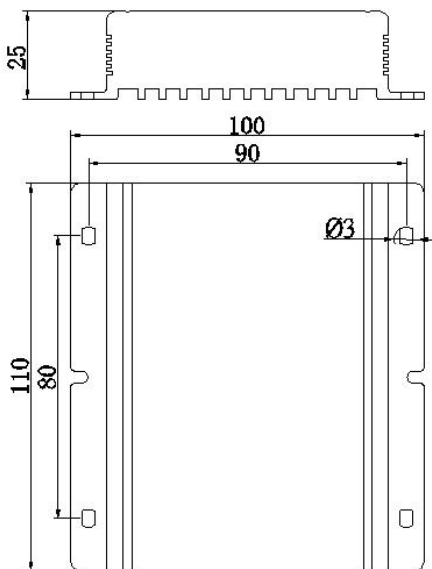

SDN-150W-EX-MV; SDN-200W-EX-MV;  
SDN-150W-EX-IR; SDN-200W-EX-IR;

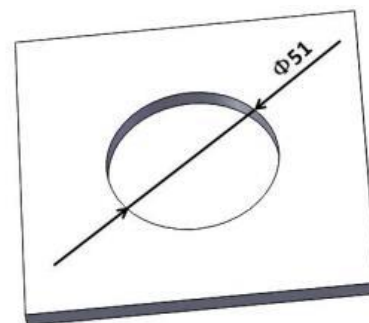
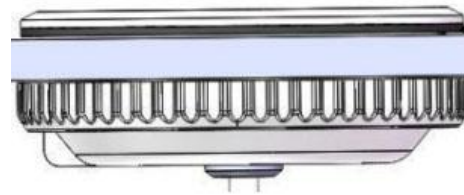

Motion Sensor of Microwave & Infrared

Figure 1.4 Product appearance

# Installation

## 2.1 Panel Introduction

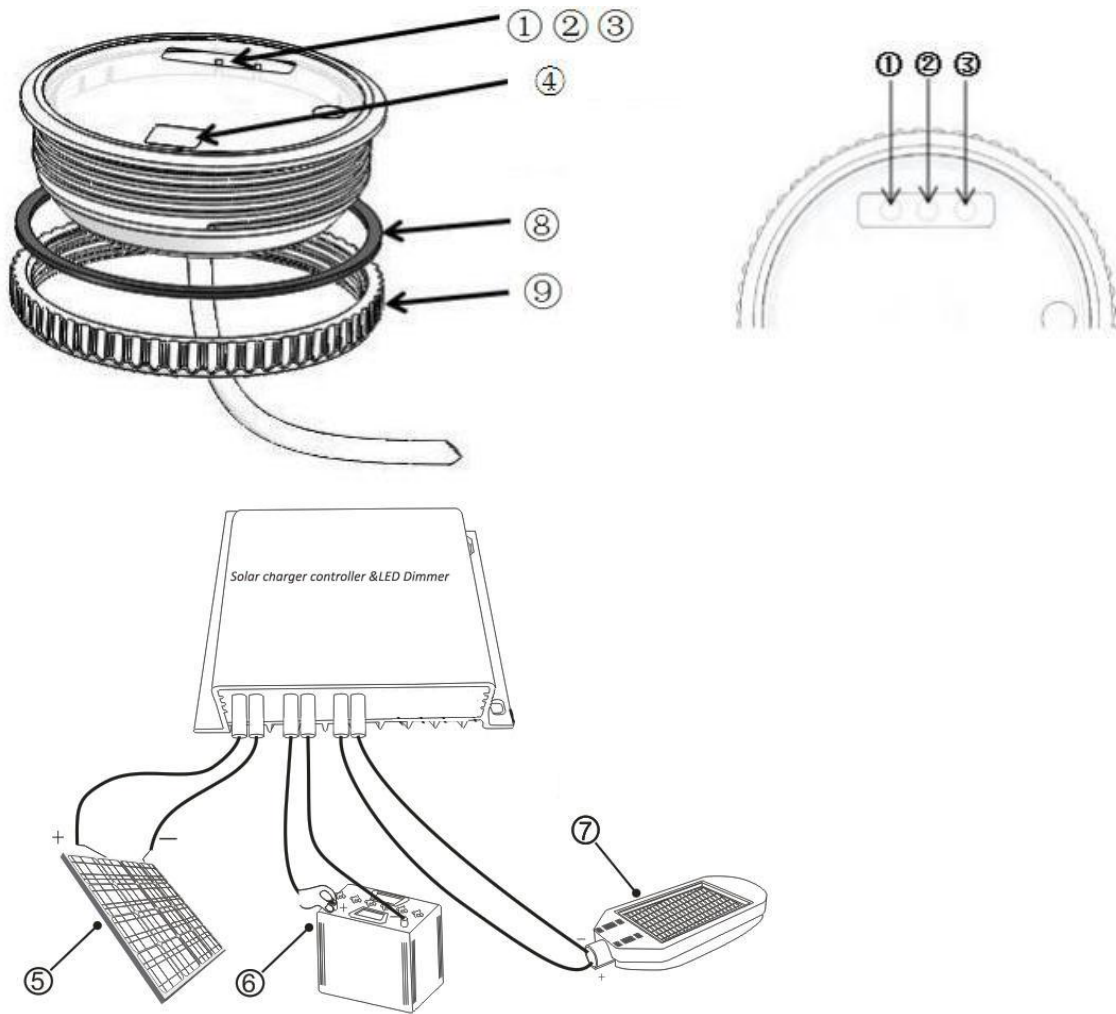

- ① PV indicator (green)
- ③ Load indicator (yellow)
- ⑤ PV connection terminal
- ⑦ Load connection terminal
- ⑨ Install catch

- ② Battery indicator (red/green)
- ④ IR communication connector
- ⑥ Battery connection terminal
- ⑧ waterproof sealing ring

---

## **2.2 LED Indicators**

### **A,PV Indicator**

| Color | Indication | Working State                                    |
|-------|------------|--|
| Green | On Solid   | PV is charging Battery                           |
| Green | Flash Fast | Battery Over Voltage, refer to Trouble shooting. |
| ---   | OFF        | PV voltage is low                                |

### **B,Battery Indicator**

| Color  | Indication | Working State                                  |
|--------|------------|--|
| Green  | On Solid   | Battery is Normal                              |
| Green  | Flash      | Battery is full                                |
| Yellow | On Solid   | Battery is under voltage                       |
| Red    | On Solid   | Battery is over-discharged, turn off Load auto |

### **C,Load Indicator**

| Color  | Indication | Working State   |
|--------|------------|---|
| Yellow | On Solid   | Load is ON  |
| --     | OFF        | Load is off   |
| Yellow | Flash Fast | Load short circuit or open circuit  |
| Yellow | Flast Slow | Load led chaps series number is too low<br>Or overload limited power output |



---

### **2.3 Fix the controller**

Fix the controller at a place free of direct sunlight, high temperature, and immersion risks. Take care of the radiator under the device, which is used to decrease device temperature during full-power operation. Measures should be taken to avoid obstruction and to ensure heat dissipation through natural convection. For installations in confined space such as lamp post, the radiator ribs should be preferably oriented along the air flow direction.

### **2.4 Connection method**

A connection method commonly used by electricians is recommended below. Please connect each wire of the controller according to standard procedures.

- All delivered wires for the controller have reserved cuts, which facilitate easy stripping during connection while preventing short circuit due to contact between wires. Please follow the steps below during installation and avoid removing insulation of all six wires at one time.

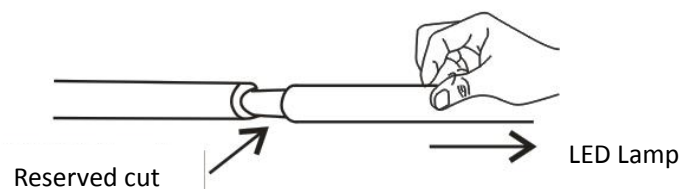

Figure 3.2 First step during wiring – wire stripping

- Cross the copper wires in the controller lead and load lead, and then twist them around the rear section of each other and tighten them.

---

This wiring method provides a large contact area and a high connection force, thus ensuring long-time reliable connection. The connectors should be tightened as well. The wires should be preferably fixed with cable ties to prevent loosening of connectors during wire vibration in mobile applications.

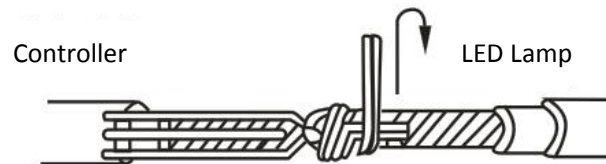

Figure 3.2.1 Second step during wiring - connection

- Use waterproof insulation tapes to wrap around exposed parts of wires. To ensure their reliability, high-pressure rubber self-adhesive tapes can be used as the inner wrapping layer and electrical tapes as outer layer. Measures should be taken to prevent aging and falling of the electrical tapes and consequent short-circuit accidents due to long-time use in humid and hot environments.



Figure 3.2.2 Third step during wiring – wrapping of insulation layers

Standard wiring is critical for long-time reliable system operations. Loose or unstable wire connections may lead to excessive resistance and consequent heating at connection parts. In these occasions, the wire insulations tend to experience premature aging, which will in turn lead to short circuit, open circuit, and other failures.

---

## **2.5 Connection Step**

For the sake of safety, please complete wiring in the following order:

①load, ② battery, ③pv

- Load connection: As the controller has not started operation, there is no response from the controller after load connection.

- Battery connection: Before connection of the battery, make sure that the battery voltage is higher than 9V so that the controller can be started. For a 24V system, make sure that the battery voltage is not lower than 18V. After completion of battery connection, the controller will start to work. 10s later, the load will be light up automatically to confirm correct wiring.

- Solar panel connection: The controller can be used for both standard 12V or 24V solar panel components and those with an open-circuit input voltage not exceeding the specified maximum input voltage. The voltage at the highest power point of solar components should not be lower than the battery voltage.

# Instructions

## 3.1 Charge Description

**Charging of lead acid or gel battery:** The controller manages battery charging based on specified charging curves for different types of cells and settings. If the cell type defined in the controller is lead acid or gel battery, the whole charging process includes three phases: Fast charge stage, equaliz charge stage, and float charge stage.

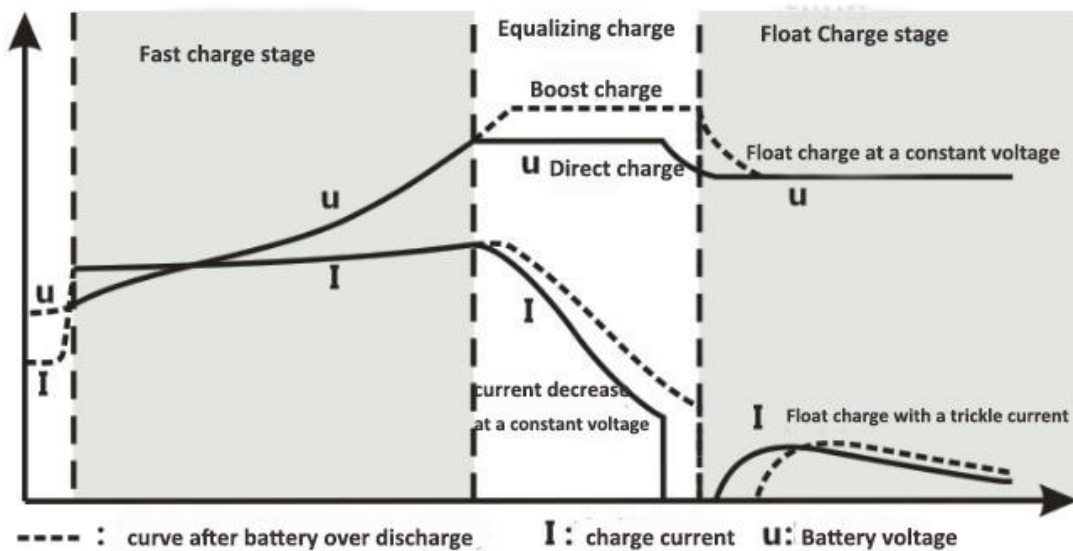

### 3.1.1 Gel/lead acid battery

- Trickle pre-charge stage: at the beginning of charging. If the battery voltage is too low, in order to protect the battery, to avoid large current impact caused damage to the internal structure of the battery. The controller will charge battery in a small current. And will enter fast charge stage after the battery voltage be some improvement.

- Fast charge stage: The battery voltage has not reached the setting, and the controller will provide the maximum solar power to charge the battery. During Fast charging, the solar panel and the battery are connected directly. The voltage of the solar panel is clamped at the

battery voltage.

- Equalize charge stage: When the equalizing charge voltage is reached, pulse width modulation (PWM) is activated. When the battery voltage reaches the setting, the controller continues to adjust battery voltage to maintain it at the setting and prevent over-charging of battery. and this stage will keep 2 hours then enter Float charge stage.

- Float charge stage: In this phase, the battery requires no further power, but the controller still provides weak charging to meet power consumption needs of small loads and to make up for power consumption by the battery itself. In this way, the battery is always kept at a saturated state for a longer service life.

**Charging of Lithium battery:** When the battery type selected for the lithium battery, the controller of the charging curve to be adjusted to accommodate the lithium battery charging characteristic.

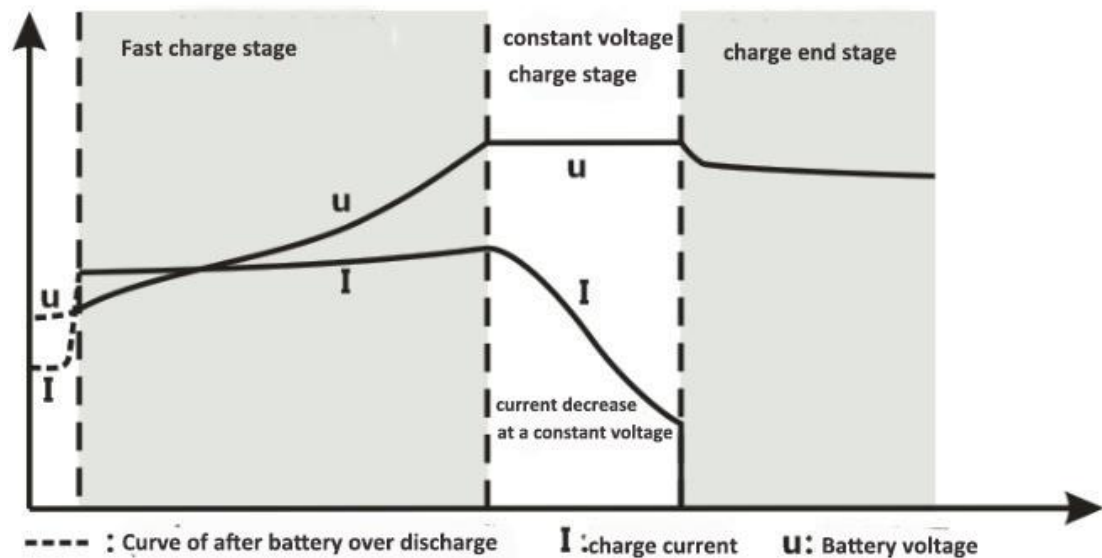

### 3.1.2 Lithium battery

- Trickle pre-charge stage: at the beginning of charging. If the battery voltage is too low, in order to protect the battery, to avoid large current impact caused damage to the internal structure of the battery. The controller will charge battery in a small current. And will enter fast

---

charge stage after the battery voltage be some improvement.

- Fast charge stage: The battery voltage has not reached the setting, and the controller will provide the maximum solar power to charge the battery. During Fast charging, the solar panel and the battery are connected directly. The voltage of the solar panel is clamped at the battery voltage.

- Constant-voltage charge stage: The constant-current charge phase ends when the cell voltage rises to a predefined level, followed by a constant-voltage charge phase. Depending on saturation degree of the battery cell, the current drops from the maximum level gradually as the charging process proceeds. This charge voltage is typically defined as 4.2V for a single-string battery. The specific voltage should be set according to the parameters provided by the battery manufacturer. (C is a notation representing correspondence between cell nominal capacity and current. For example, for a cell capacity of 1000mAh, 1C means a charging current of 1000mA.)

- Charge end stage: The charging current during the constant-voltage charge phase is monitored, and the charging process is ended when the charging current drops to the end-of-charge current, which is typically 0.02C

### **3.2 Discharge Description**

#### **(1) Discharge operation mode:**

The controller can run automatically and unattended by following a preset mode. The controller provides four operation modes:

- Light-control mode: when dark, the solar panel voltage will drop to the start point. After a predefined delay time , the controller confirms the startup signals to switch on the load for operation; At dawn, after the

---

light intensity has risen above the start point and a predefined delay time has elapsed, the controller confirms the shutdown signals to switch off output, and the load will stop operation.

- Testing mode: This mode is used for system testing. It's almost the same as complete light-control mode. The only difference is elimination of the delay time before optical signal determination, and all other functions are preserved to facilitate checking of proper system functions during installation and testing.

- Manual mode: In this mode, the output on load side is switched on or off manually. Switching operations are performed by pressing the function key(F1) on the remote controller.

- Automatic mode: This mode provides both light-control and timer functions. In the absence of sunlight, the light intensity will drop to the start point. After a predefined delay time, the controller will confirm the start signals and the load will be switched on. At this point, the timing sequence starts. When the total time reaches the sum of time settings for the first to five periods, the load will be switched off. Before dawn, the controller restarts this six-period , and the load is switched on till day break. As the daily sunshine time varies with season, the specific time settings for the six periods also change to keep ahead of day break.

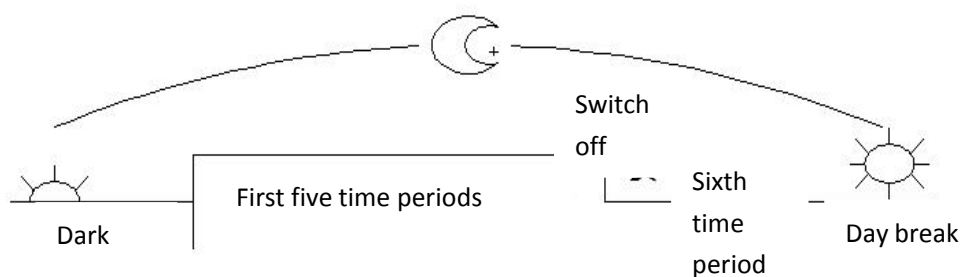

Figure 3.2 Automatic mode diagram

In automatic mode, the output current depend on current setting of

---

the different period. In other modes, the output current depend on current setting of the first time period.

## (2) Smart mode

Including smart energy-saving mode ( modes 1 to 4) and external motion sensor mode (modes 5 and 6). In smart energy-saving mode, automatic power reduction control is provided based on current battery charge and ambient temperature variations to prevent over discharging and improve battery service life. This mode is ideal for different series of solar control constant-current integrated machines. The power reduction amount is given below. The specific settings should be made according to actual needs.

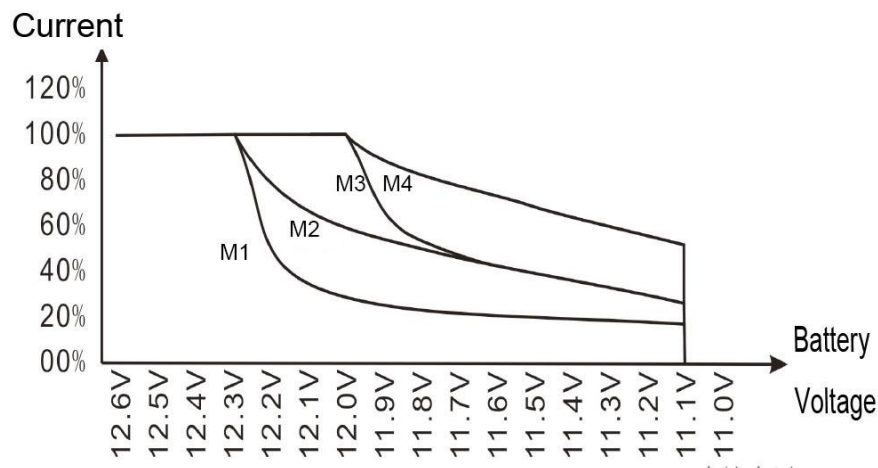

For (M5,M6),this work mode is for motion sensor for human being and radar to adjust the output for LED lamp auto,

In the mode of M5,when nobody nearby,the output current lower to 50mA,

In the mode of M6,when nobody nearby,the output is 0(Lamp is off),when human being comes nearby,output current will boost to the setting value to turn on the LED lamp.



Diagram of motion sensor distance

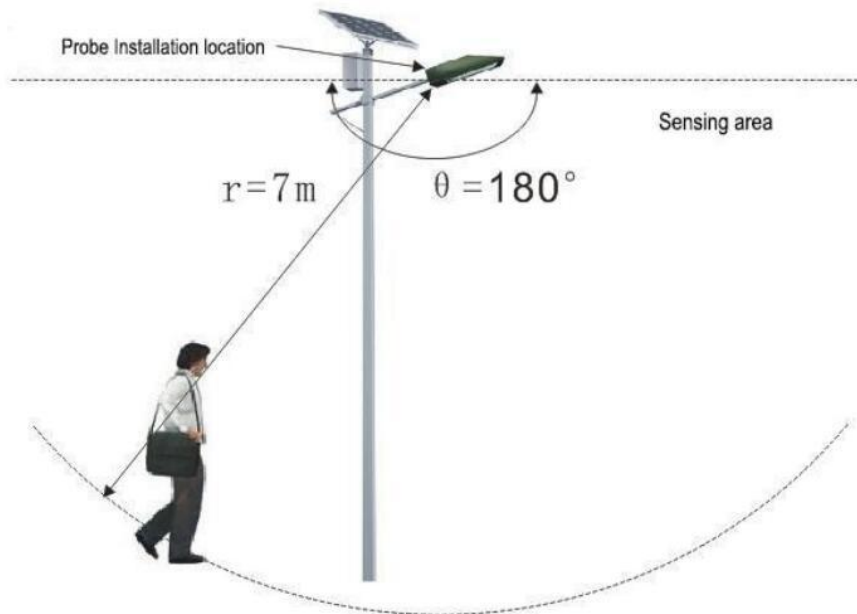

Microwave motion sensor Inductive range diagram

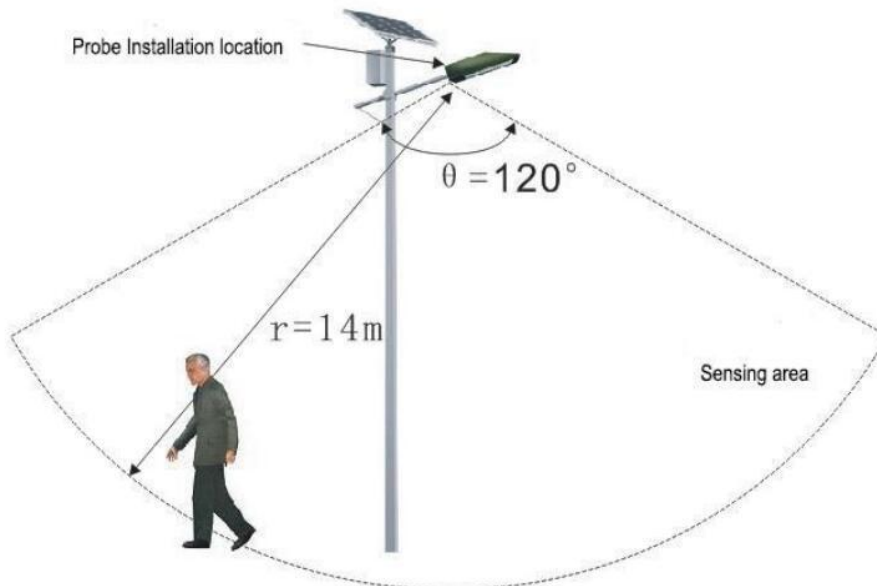

Infrared motion sensor Inductive range diagram





## Trouble Shooting

| Phenomenon  | Analysis   | Solutions  |
|---|--|--|
| <ul style="list-style-type: none"> <li>·In daytime,PV indicator is dark</li> <li>·In daytime,Load is on</li> <li>·Load work only for the one whole night</li> </ul> | <ul style="list-style-type: none"> <li>·solar panel cables Connection mistake.</li> </ul>  | <ul style="list-style-type: none"> <li>·check solar panel cables connection is correct or not.</li> <li>·cut off the solar panel cables connection it again.</li> </ul>  |
| <ul style="list-style-type: none"> <li>·Load Indicator flash fast &amp; LED lamp not work.</li> </ul>   | <ul style="list-style-type: none"> <li>·LED lamp cable is open circuit or short circuit.</li> <li>·LED lamp is broken</li> </ul>             | <ul style="list-style-type: none"> <li>·recheck the LED lamp cables connection is correct or not.</li> <li>·cut off LED lamp connection cables,then reconnect.</li> </ul>  |
| <ul style="list-style-type: none"> <li>·Load Indicator flash fast &amp; LED lamp flash also.</li> </ul>   | <ul style="list-style-type: none"> <li>LED chips connection not meet driver range.series number too much or too low</li> </ul>               | <ul style="list-style-type: none"> <li>·refer to parameter table to adjust the LED chips connection.</li> </ul>  |
| <ul style="list-style-type: none"> <li>·Load Indicator flash slowly</li> </ul>  | <ul style="list-style-type: none"> <li>·Output power over the controller rated power</li> </ul>  | <ul style="list-style-type: none"> <li>·Low down the output current</li> </ul>   |
| <ul style="list-style-type: none"> <li>·Battery indicator is red</li> <li>·LED turn on for a short time.</li> </ul>   | <ul style="list-style-type: none"> <li>·Battery voltage is low 。</li> <li>·Cables resistance is too big or the battery is damaged</li> </ul> | <ul style="list-style-type: none"> <li>·If this occurs often,then need to check PV charging is normal or not,solar panel is blocked or not,or other reasons caused PV not charge normally.</li> <li>·Battery quality is good or not.</li> <li>·Check the battery cables is too long or if there is any connection</li> </ul> |

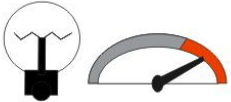
|  |  |                      |
|--|--|----------------------|
|  |  | not good to battery. |
|--|--|----------------------|

## Protection

|   |   |
|---|---|
|  | <p><u>Load Fault:</u></p> <p>In case of any short circuit or open circuit in the controller load connections, the controller will provide automatic protection, and the load indicator will flash rapidly. The system detects the load fault at a regular interval to determine if it has been eliminated. If the fault persists for over 7 minutes, the controller will make no further attempts to switch on the load until another attempt is made on the next day, or a manual switch-on operation will be made after the fault has been eliminated by maintenance personnel.</p> |
|  | <p><u>Over Power Protection:</u></p> <p>When the load power exceeds the rated power by 5%, power protective mode will be initiated to prevent damage to the controller.</p>   |

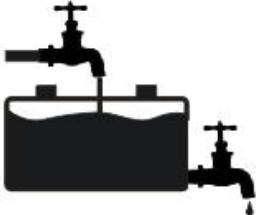
|   |   |
|---|---|
|    | <p><u>Over Charge Protection:</u><br/>When charging the battery voltage is too high, the controller will automatically disconnect the charging circuit, in order to avoid damage to the battery.</p>  |
|    | <p><u>Over Discharge protection:</u><br/>When battery voltage discharge too low, controller will cut off the load output automatically to protect battery</p>   |
|    | <p><u>PV modules reverse polarity protection:</u><br/>When PV modules reverse polarity (NOT suggested), the controller will not be damaged, will continue to work after the correction of wiring errors.</p>  |
|    | <p><u>Battery polarity protection:</u><br/>When battery reverse polarity (NOT suggested), the controller will not be damaged, will continue to work after the correction of wiring errors.</p>  |
|  | <p><u>Temperature sensor damage fault protection:</u><br/>When the temperature sensor short circuit or damage, the controller will default working at 25 °C. In order to avoid battery errors and damage caused by "broken" temperature compensation.</p> |
|  | <p><u>Over-current protection:</u><br/>A over-current (1.25 times rated current) protection with 60s delay is provided with inverse time lag characteristics.</p>   |

---

## IR Remote Control

### 6.1 Diagram

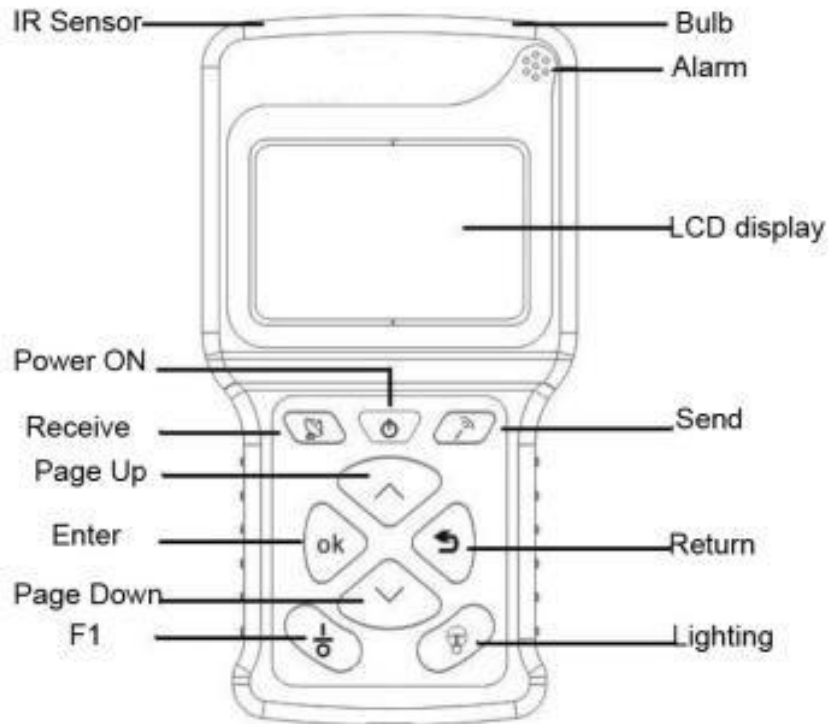

### 6.2 Operation of remote control

#### Power ON/OFF

Press "Power" button continue for 3 seconds to start up the remote control,for power off,just leave the remote control without any operations for 5minutes,then it will be power off automatically.Or you can press "Lighting"button continue for 3 seconds for Power OFF.

---

## LCD Screen Display after Power ON

### 1.Setting

Parameters setting for all the models of controllers,including battery specification and other charge and discharge parameters,also you can set the work mode of output here.

### 2 .Real-Time Data

Real-time data for all the controllers that is working now,all the value on the LCD screen display is real-time.

### 3. System Setting

Remote control system setting,Including Remote Style,Language, Alarm,Factory Reset and Edition.

## Receive and Send Signal to controller

RC-3 Remote control transfer signal by infrared,the distance indoor can be 10-15m,and outdoor will be shorter for environment difference.

Press “Receive”button to get the signal from working controller,you can know what kind of work mode is saved inside of controller.you can page up and down to check all the parameters of working controller.

After set all the parameters well,and make the remote control face to the controller that need to be set,press “Send” button,controller will receive the signal from remote control,after recheck inside controller with no problem,3 indicators on the controller will flash all together for one time,meaning that sending signal successfully.the same time,some

---

controllers will send back the successful signal to the remote control again,after remote control get the signal,alarm will work for reminding.

(Attention:sometimes remote control will not get signal from controller,and LCD screen will show “communication over time”,and remote control will make sound “DI DI DI”for 3 times,reasons are that the distance is too far,the angle not correct or occlusion of some other object between remote control and controller).

### Lighting

After Power ON the remote control,you can press “lighting”button for lighting in the night,press one more time again for off.

### Parameter changing

When enter into the setting mode,press “O.K”button to change the value of each parameter,when it flash,meaning enter into the editable status,you can change the parameter by press page up or down button,after set well,press “O.K”button to save the value.the same time,the parameter will stop flashing,and you can press “Return” button to be back to previous menu.

(if the parameter is flashing,and you press “return”button,the data will not be saved)

---

### **6.3 Introduction for different controller models**

This type remote control fit for all our products that support IR function,like solar charge controller,solar controller inbuilt LED driver,grid solar hybrid controller,LED driver, etc.the parameters of each controller is different,please set the value according to the controller that you installed.once you set the parameters over the range of the controllers,the controller will not receive the signal from remote control,you can reference to the chart in the following:

| Controller Type                      | Corresponding model         |        |
|--------------------------------------|-----------------------------|--------|
| Solar Controller built in LED Driver | SDN series、 SDN-M series    |        |
| Solar Charge Controller              | SDN-P series、 SDN-MP series |        |
| Solar Utility hybrid controller      | SDH series.SDH-P series     |        |
| Parameter settings                   |                             |        |
| Item                                 | Parameter setting range     | Remark |
| 1st period working time(Hours)       | 00: 00~09:50                |        |
| 1st period working power(Current)    | 0mA-8000mA                  |        |
| 2nd period working Hour(Hours)       | 00: 00~09:50                |        |
| 2nd period working power(current)    | 0mA-8000mA                  |        |
| 3rd period working time(Hours)       | 00: 00~09:50                |        |
| 3rd period working power(current)    | 0mA-8000mA                  |        |
| 4th period working time(Hours)       | 00: 00~09:50                |        |
| 4th period working power(current)    | 0mA-8000mA                  |        |



|   |                                    |   |
|---|------------------------------------|---|
| 5th period working time(Hours)  | 00: 00~09:50                       |   |
| 5th period working power(current)   | 0mA-8000mA                         |   |
| Morning Period Time(Hours)  | 00: 00~09:50                       |   |
| Morning Period Time power(current)  | 0mA-8000mA                         |   |
| Work mode   | Manual/auto/testing/light control  |   |
| Smart Control   | Off/M1/M2/M3/M4/M5/M6              |   |
| Note: Difference of M1-M6 refer to 7.0 Appendix.  |                                    |   |
| Set charge  | ON/OFF                             |   |
| If "Set charge" is off, the following items will not be shown on the remote while program |                                    |   |
| Light control delay time  | 20s or 2~60min.                    |   |
| Light control voltage   | 3.5~10V                            |   |
| Battery type  | Lead-acid / Gel/<br>Lithium/custom |   |
| System voltage  | 12v or 24v                         | For Lithium<br>Battery set,<br>auto x2<br>when set<br>voltage<br>24V. |
| Over voltage  | 15.0~20.0V                         |   |
| Over discharge  | 8.0~20.0V                          |   |
| Over discharge return voltage   | 10~20.0V                           |   |
| charge voltage  | 10.0V~20.0V                        |   |
| Charge Current  | 0.1A-20A                           |   |
| Charge End Current  | 0.1A-20A                           |   |
| Charge Temperature  |                                    |   |

|                               |           |  |
|-------------------------------|-----------|--|
| Discharge Temperature         |           |  |
| Over voltage                  | 15-20v    | Only For<br>Custom<br>Battery<br>type<br>setting |
| Over discharge                | 8.0~20.0V |  |
| Over discharge return voltage | 10~20.0V  |  |
| Boost Charge                  | 10~20.0V  |  |
| Float Charge                  | 10~20.0V  |  |

#### **6.4 Real-Time Data**

After enter into this mode,remote control will receive the signal from working controller automatically,and display the working status and specification of PV,battery,load,total capacity charged and discharged,temperature etc.Only make sure that the communication is reliable and effective.

#### **6.5 System Setting**

##### 1,Remote Style

Brief:set parts of main parameter of controller easily.

Standard:set all the parameter in this mode.

For remote style changing,you can use with page up and down,or you can press “F1”button continue for 3 seconds.

##### 2,Language

Chinese/English for changing

##### 3, Alarm

You can turn ON/OFF sound of remote for reminding.

---

#### 4 ,Factory Reset

One button to make factory reset if you have any problem during application.

#### 5, Edition

The edition of remote control

### **6.6 Additional function**

This remote control support the locking function,you can press “F1”+”Lighting” buttons together to lock/unlock the remote,after lock the remote,you can only send the signal to controller or receive the signal from controller,all the parameters of remote can’t be programming in lock status.this function to avoid the workers to change the parameters by mistake.

### **6.7 Appendix**

#### 1, Work mode:Manual,Auto,L-Ctrl,Testing

Manual:turn ON/OFF the load by pressing “F1”button.

Auto:light control+timer,work for all time periods.

L-Ctrl:the load will work during sun set and sun rise,work the whole night.

Testing:testing for system without any time delay after sunset.

#### 2,Smart mode

Including the smart work mode,(M1,M2,M3,M4),and external motion

Sensor function mode(M5,M6).

---

## Warranty

### Warranty Card

Product Name

Product Model

Serial number

Date of purchase: \_\_\_\_Date\_\_\_\_Month\_\_\_\_Year

Company Name:

Contact:

Address:

Tel:

1. The product warranty period is three years since factory.
2. During the warranty period, any problem caused by normal use under the user manual (determined by the controller factory), reparation is free of charge.